

## READ AND FOLLOW ALL INSTRUCTIONS



### WARNING!

DO NOT PERMIT CHILDREN TO OPERATE THIS PRODUCT WITHOUT CONSTANT SUPERVISION.



### WARNING!

REMOVE STANDING WATER FROM THE TOP OF THE COVER. WATER ON TOP OF THE COVER IS A DROWNING RISK.



### WARNING!

NEVER OPERATE THE COVER WHILE THERE IS SOMEONE IN THE POOL.



### WARNING!

NEVER LEAVE THE COVER PARTIALLY OPEN.



### WARNING!

ALL ELECTRICAL CONNECTIONS SHOULD BE MADE BY A LICENSED ELECTRICIAN IN ACCORDANCE WITH ALL APPLICABLE LOCAL AND NATIONAL CODE.

This cover system has been designed and manufactured to meet or exceed the American Society for Testing and Materials Standard F1346-91. ASTM f1346-91 establishes requirements for all swimming pool and spa safety covers.

The cover meets the A.S.T.M. F1346 standards only if the installer uses all the materials provided by the manufacturer in the manner prescribed. Particular attention must be paid in following the manufacturer's instructions for the installation of the locking device to prevent unwanted entry by a small child. In addition, all outside installations must employ a cover pump to automatically remove rainwater from the surface of the cover. Pools of rainwater that may accumulate on top of the cover are also a drowning hazard that must be addressed in order to meet the A.S.T.M. criteria.

## SAVE THESE INSTRUCTIONS

**Section 1: Parts List**

**Below Deck Automatic Retractable Security Cover Kit**

- (1) Tube End Bearing Plate (A)
- (1) Rope Reel and Cover Drum Motor Assembly (B)
- (1) Cover Drum
- (1) Pulley Support Channel
- (2) 2 Lengths of Combination In-Wall Cover Track and Liner Track connected by Internal Ropes (C)
- (1) Length of Combination In-Wall Cover Track and Liner Track without internal track or rope
- (1) Length of Pre-Determined Length of Extrusion Snap-In Face
- (4) Inside Corner Assembly Kit (packaged separately in crate) (D)
- (1) Length of Liner Hanger/Pool Panel Cover
- (2) Lengths of Pre-determined Hydraulic Run Hose
- (1) Power Unit with Key Switch Attached
- (1) Cover Fabric
- (1) Leading Edge
- (1) Hardware Kit
- (1) Gallons of Hydraulic Fluid
- (2) Front Panel C Brackets (Pools 9' (2,73m) or wider get three) (E)
- (2) Front Panel Flat Brackets (Pools 9' (2,73m) or wider get three) (F)



A



B



C



D



E



F

**Tools Required (supplied by others)**

- |                             |                                      |
|-----------------------------|--------------------------------------|
| Power Drill                 | Tape Measure                         |
| Phillips Head Bit           | 7/16" (11mm) Wrench or Socket Wrench |
| 5/16" (8mm) Nut Driver Bit  | 1/2" (13mm) Wrench or Socket Wrench  |
| 11/64" (4mm) Drill Bit      | 9/16" (14mm) Wrench or Socket Wrench |
| 5/16" Drill Bit             | <b>3/4" (19mm) Wrench</b>            |
| Phillips Head Screwdriver   | 3/16" (5mm) Hex Head Wrench          |
| Regular Screwdriver         | 3/32" (2mm) Hex Head Wrench          |
| 3' (91cm) Carpenter's Level | <b>Hammer</b>                        |

**Section 2: Description**

The Below Deck Automatic Retractable Security Cover (BDARSC) acts as a horizontal fence keeping children and pets out of the pool while controlling humidity. Operated with a turn of a key, the cover automatically retracts for convenient access to your pool. The BDARSC is available for all standard pool widths. All moving components are hidden behind the front panel.

**Section 3: Placement Considerations**

The BDARSC must be mounted at the front of the pool. A minimum of 24" (61cm) horizontal clearance is required at the front of the pool for the Drive Mechanism. The combination in-wall cover track and liner hanger will raise the coping off the reinforcing channel by 2-1/8" (54mm). The coping or other finish material covering the front edge of the pool must be constructed so to not interfere with the operation of the cover (See Fig 19 and Fig 20 on page 16&17).

- At a minimum, access must be maintained in the finished work for the track end guides at the front corners of the pool. Ideally, there should be access to the entire cover mechanism.
- A minimum of 6" of clearance must be maintained to access the rope reel (Fig 21). Refer to Detail Drawing EP-6.11.

**Section 4: Installation Instructions**

**THESE INSTRUCTIONS DEVIATE FROM THE ENDLESS POOL ORIENTATION. ALL ENDLESS POOLS DOCUMENTATION REFERS TO LEFT AND RIGHT AS SWIMMING IN THE POOL. THESE INSTRUCTIONS REFER TO LEFT AND RIGHT STANDING BEHIND THE FRONT OF THE POOL LOOKING TOWARDS THE BACK OF THE POOL.**

**Assembly of the Cover Drum**

1. The cover drum has 2 specific end hubs (the tapered Aluminum castings at each end of the cover drum).

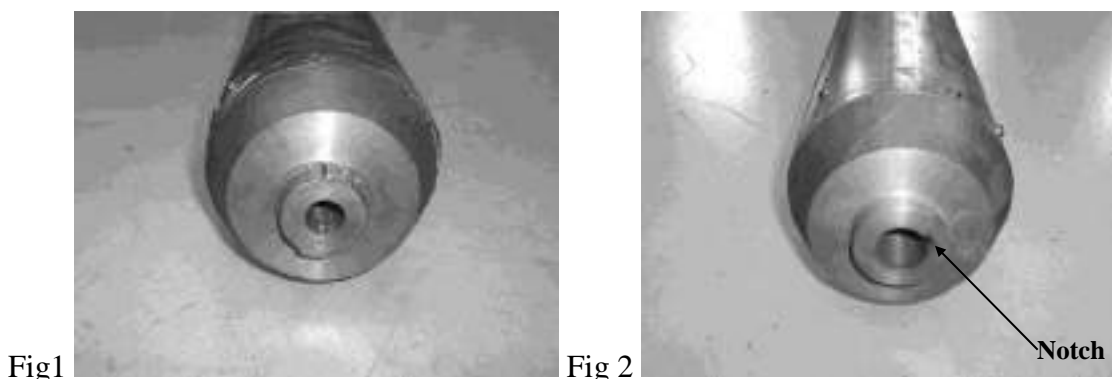

2. The end that has the notched hole attaches to the drum motor (Fig 2) and the end without the notch is for drum pin (Fig 1). Note: the drum pin may already be attached.

- 3. Remove the drum motor hub by loosening the six screws that hold it in place. Line up the notch in the hub with the drum motor shaft key and lightly tap the hub onto the shaft of the motor. Secure the hub onto motor shaft by threading in the provided 3/16" (5mm) hex-head screw. (Fig 3)

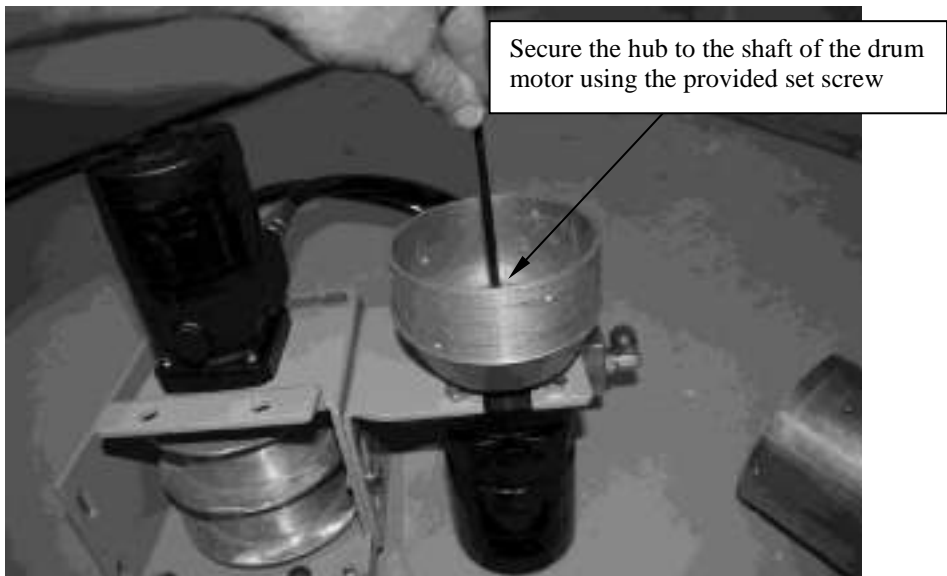

Fig 3

- 4. If not done so already, at the opposite end of the drum insert the Drum Pin into the hub so that 3-1/2" (89mm) of the pin is exposed.

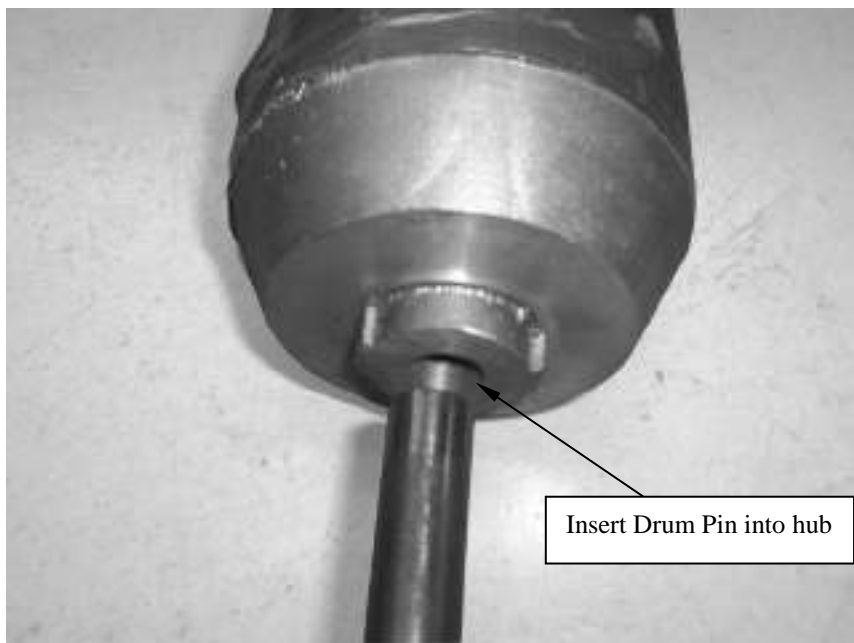

Fig 4

- 5. Secure the Pin into the hub by tightening down the 2 set screws in the hub with a 3/32" (2mm) hex-head wrench. (Fig 4)

**Assembly of the Drive Mechanism**

1. Complete the Endless Pool Assembly Instructions up to but not including "Liner Hanger."
2. **When attaching Automatic Cover parts to the pool use the panel nuts and bolts. When attaching Automatic cover parts to other Automatic parts use the provided hardware.** On the right side of the front panel, remove the top corner angle and install the tube bearing plate, using the nuts and bolts for the pool panel. Do not tighten. (See Fig 5)

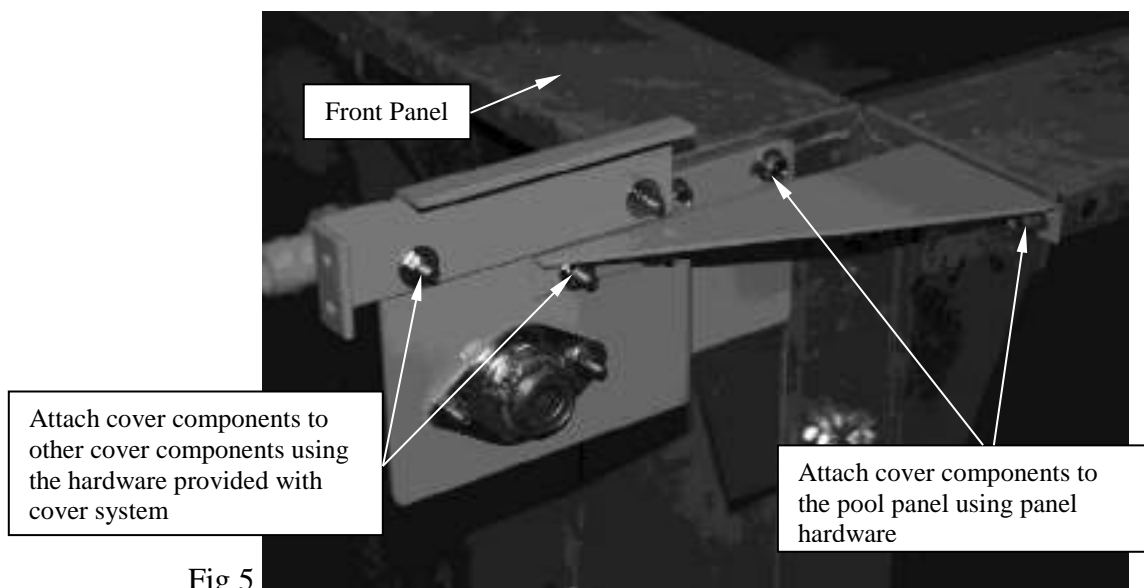

Fig 5

3. The cover reel and drum motor assembly will be attached to the front left corner of the pool, but first needs to be temporarily disassembled. Disconnect the two short hoses that are connecting the reel motor to the drum motor manifold. Then unthread the two mounting bolts that connect the drum motor assembly to the reel motor assembly. (Fig 6)

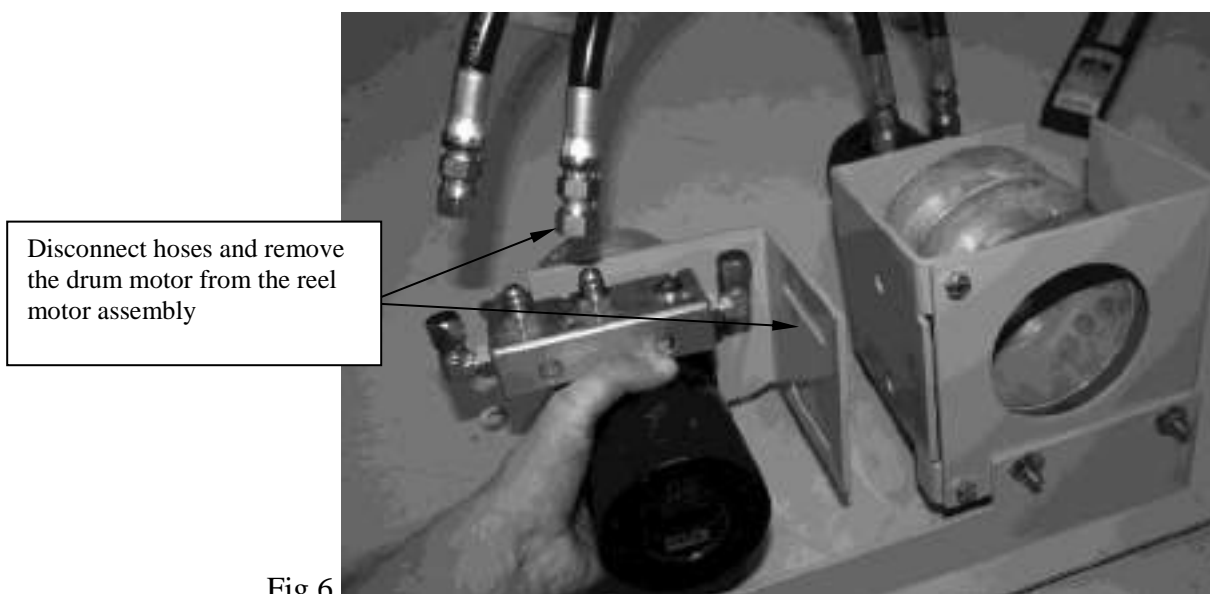

Fig 6

4. Remove the outside corner angle from the left side of the front panel and then remove the gusset from the left side of the front panel. Lift the reel motor assembly into place so that the motor is seated under the top flange. Place the outside corner back into place so that it sits between the panels and the motor assembly and replace the panel bolts but do not tighten yet. (Fig 7)

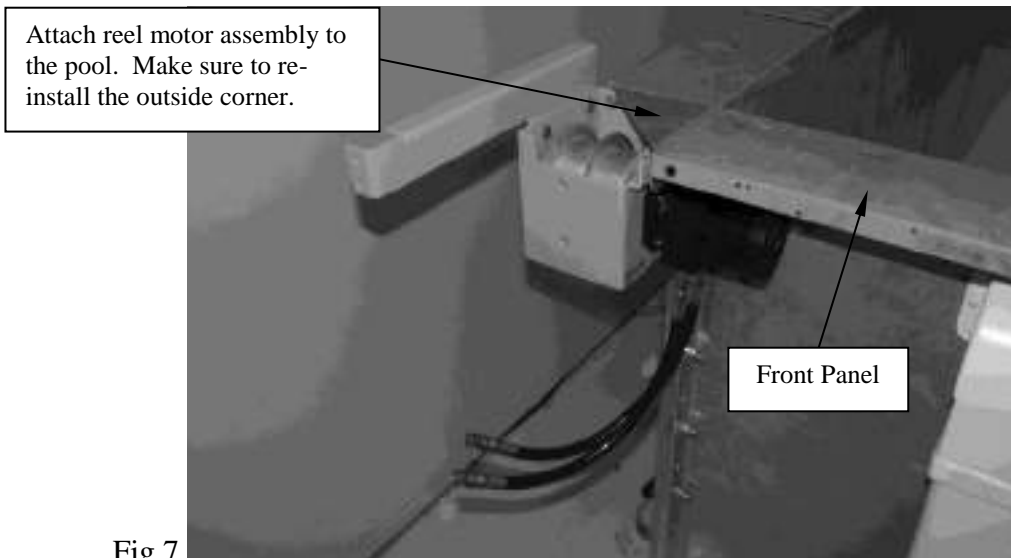

Fig 7

5. Insert the drum hub back into the drum and align the holes in the drum with the holes in the hub. Thread back in the screws that attach the hub to the drum. Wrap a small amount of duct tape over that end of the drum.
6. Lift the drum assembly into place and insert the drum pin into the tube end bearing plate. Loosely attach the two bolts that connect the drum motor assembly to the reel motor assembly. When the drive unit assembly is fully attached to the pool, tighten all the panel bolts so that both the tube end bearing plate and the motor assembly is level and flush with the top flange of the pool. Center the drum on the front panel and then tighten the drum mounting bolts. (Fig 8)

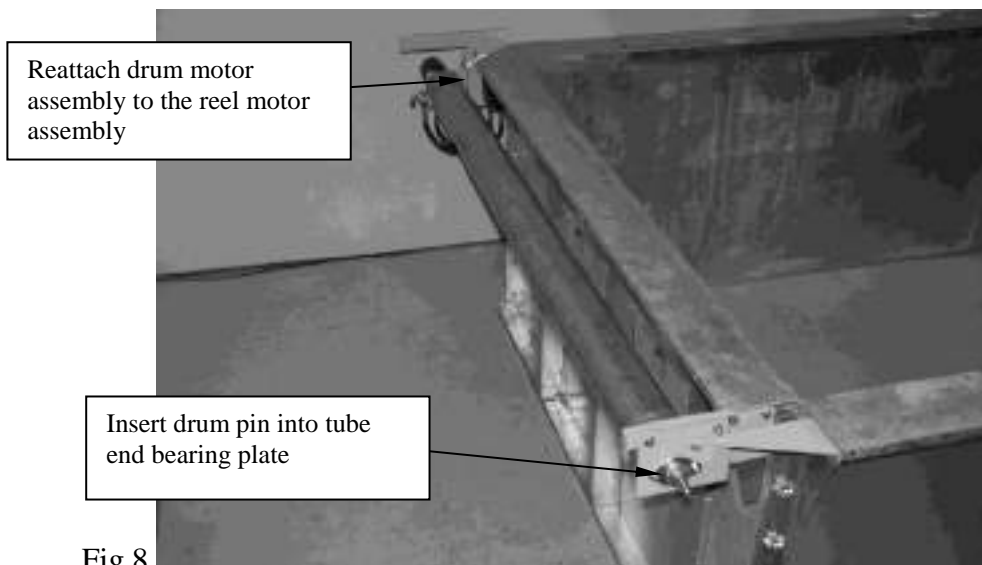

Fig 8

7. Now reconnect the two short hoses between the reel motor and the drum motor. The hose closest to the pool on the reel motor should be connected to the fitting closest to the pool on the drum motor manifold. The hose furthest from the pool on the reel motor should be connected to the fitting furthest from the pool on the drum motor manifold. (Fig 9)



**Fig 9**

**Power Unit Electrical Connections**

**1. 60Hz Power Unit Electrical Connection (US and countries with a similar power supply):**

The Power Unit has a temporary-use plug in cord attached to the hard wire conduit and a short length of conduit connected to the key switch. This allows for a temporary hook up for installation and testing to ensure the key is turning the proper components. Find a temporary 110V power source and plug in the cord. The Power Unit needs to be permanently installed by a licensed electrician using a 110 volt 20 amp GFCI breaker. The key switch conduit can be lengthened to accommodate a remote location. **The key switch must be located within eyesight of the pool.**

**AUTOMATIC COVER SYSTEM SCHEMATIC 60Hz**

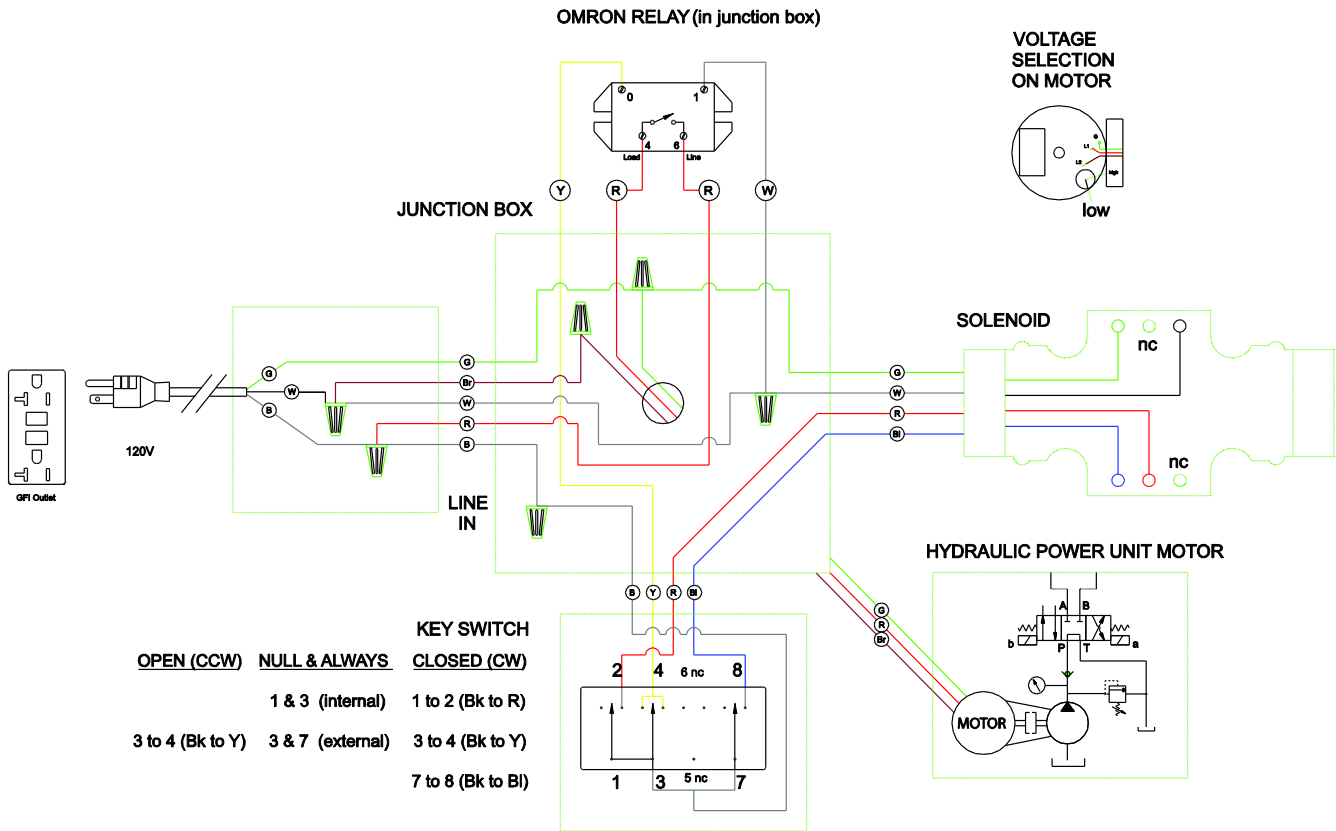



2. **50Hz Power Unit Electrical Connection (UK and countries with a similar power supply):**

The power unit must be supplied with a 220v 15amp RCD-protected power supply. A C-type, D-type, or motor rated breaker **MUST** be employed. The power unit must be installed by a licensed electrician. The key switch conduit can be extended to accommodate a remote location. **The key switch must be installed within sight of the pool.**

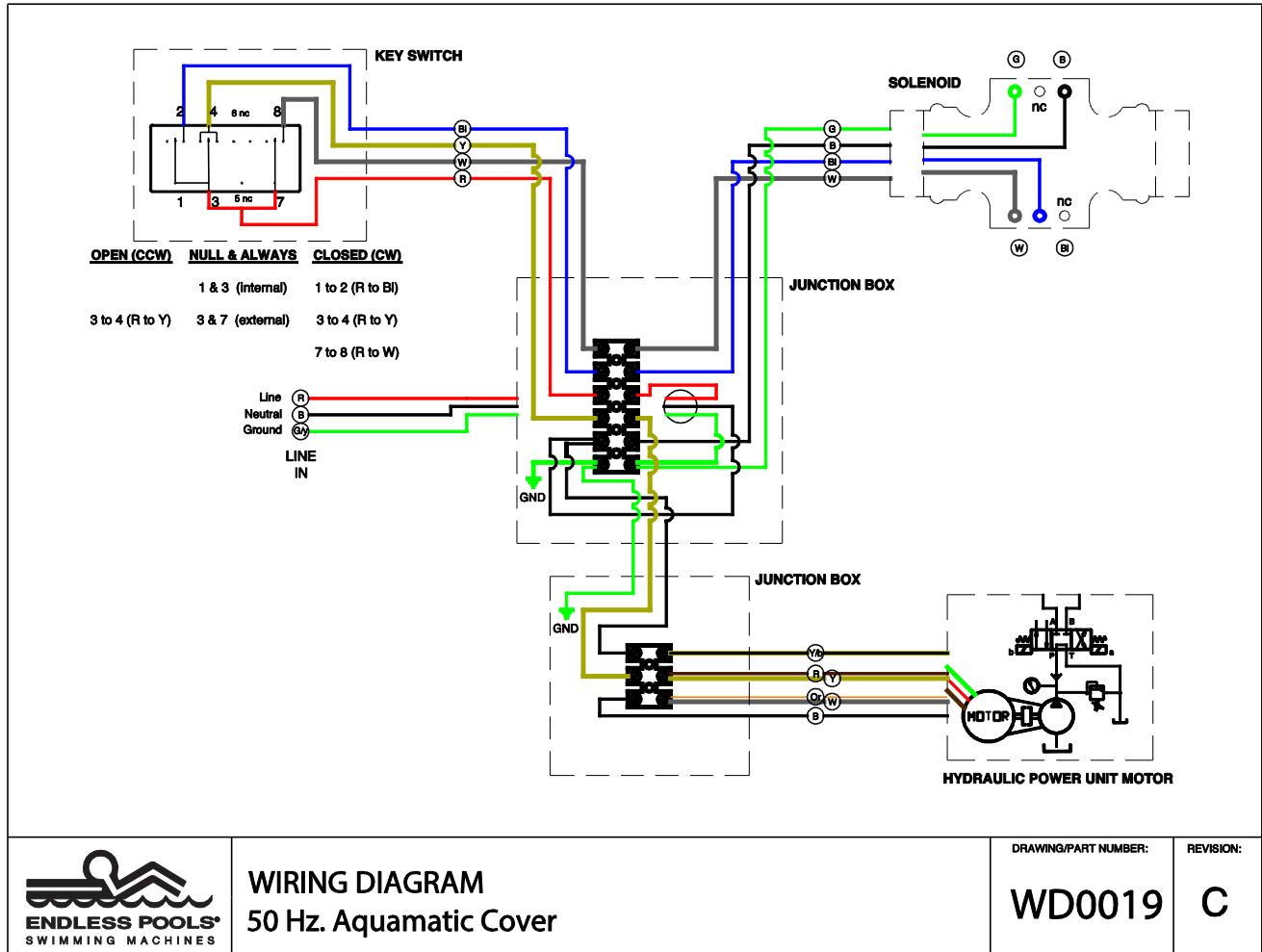

**WIRING DIAGRAM**  
50 Hz. Aquamatic Cover

DRAWING/PART NUMBER:  
**WD0019**

REVISION:  
**C**

**Installing the Hydraulics & Power Unit**

1. Attach the hydraulic run hose from the power unit to the fittings on the end of the drum motor manifold. It does not matter which hose gets attached to which fitting on the power unit.
2. A licensed electrician must make all electrical connections to the power unit in accordance with all applicable local and national electrical codes.
  - **Domestic (60Hz) Power Unit**-the power unit has a temporary-use plug-in cord attached to the incoming power supply whip. This allows for a temporary hook up for installation and testing. This unit must be hard-wired into an 110V 20amp GFCI-protected power supply by a licensed electrician. The key switch conduit can be lengthened to accommodate a remote location. The key switch must be located within eyesight of the pool.
  - **International (50Hz) Power Unit**- This unit must be hard-wired into a 220V 15amp RCD-protected power supply by a licensed electrician. The key switch conduit can be lengthened to accommodate a remote location. The key switch must be located within eyesight of the pool
3. Fill the Power Unit's reservoir with hydraulic fluid within 1" (25mm) of the top or about 3/4 gallon (3 liters). After making sure all the hydraulic fittings are tight, engage the Power Unit by turning the momentary switch to either the open or closed position. Hold the key in that position until either the rope reel or the cover drum starts to run smoothly. Turn and hold the key in the other direction until the other component turns smoothly.
4. Check the level of the hydraulic fluid within the reservoir because the hydraulic run hose has now been filled with fluid, which will have partially drained the reservoir. If needed, re-fill the reservoir to within 1" (25mm) of the top of the reservoir (35' (10,6m) of hose holds approximately 1qt (1 liter) of fluid).
5. Check the switch direction. Stand behind the front panel facing the rear of the pool. Turning the key to OPEN should cause the cover drum to turn away from the pool. Turning the key to CLOSE should cause the cable reel to turn towards the pool. If this is not the case then either reverse the hose connection at the Power Unit or switch the wiring in the key switch. To change the wiring in the key switch, shut off power to the Power Unit (Fig 10). Refer to the caption below for exact wiring instructions.

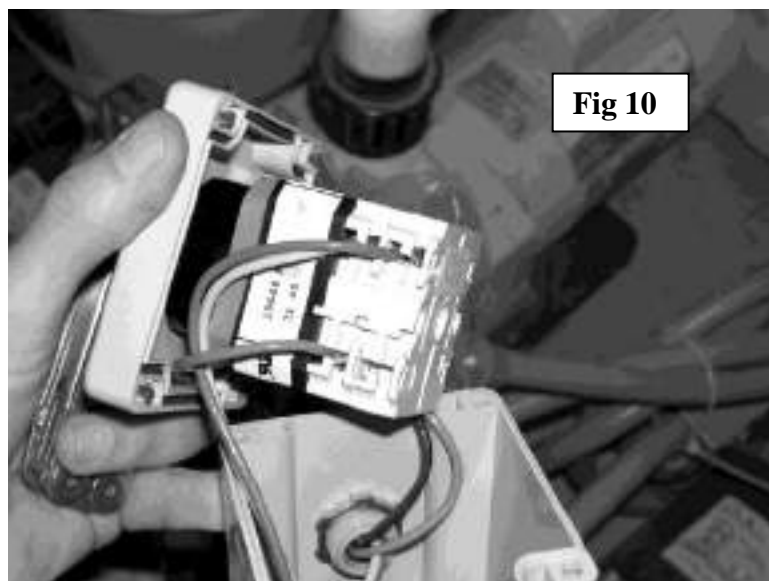
**Fig 10****Domestic (60Hz) Key Switch-**

Exchange leads 2 and 8 (red and blue) inside the key switch box.

**International (50Hz) Key Switch-**

Exchange leads 2 and 8 (blue and white) inside the key switch box.

### Installing the Combination In-Wall Cover Track and Liner Hanger

#### DO NOT SCREW DOWN ANY OF THE TRACK EXTRUSIONS UNTIL ALL ARE IN PLACE!

1. Place the 6-1/2" (16,5cm) ABS shims all around the top flange of the pool, *except* on the reinforcing channel, so that they are aligned with the inside edge of the pool. (Fig 11)
2. There are (5) lengths of combination in-wall cover track and liner hanger. There will be one extrusion that is the width of the pool (it may have the Snap-In face already installed); that goes at the rear of the pool.
3. Place the rear extrusion on the rear panel top flange with the liner hanger/cover track opening facing into the pool. The rear extrusion will be approximately 1/2" (13mm) shorter than the pool's width.
4. Place the liner hanger/pool panel cover on the front panel so that the liner hanger opening is facing in towards the pool.
5. There are two combination in-wall cover and liner track extrusions, which are connected by internal ropes, per side for a total of four sections. Each of the two sections will be folded over on themselves. On a flat surface, unfold the sections and carefully interlock the two sections. Repeat for the other set of connected sections **DO NOT CUT OR REMOVE ROPE!**
6. Once the front and rear extrusions are in place, lay down the side combination in-wall cover and liner track extrusion so the liner hanger is facing the inside of the pool and the black plastic cover guides are at the front end of the pool. At the rear of the pool the side extrusion should line up with the back edge of the rear extrusion. (Fig 11)

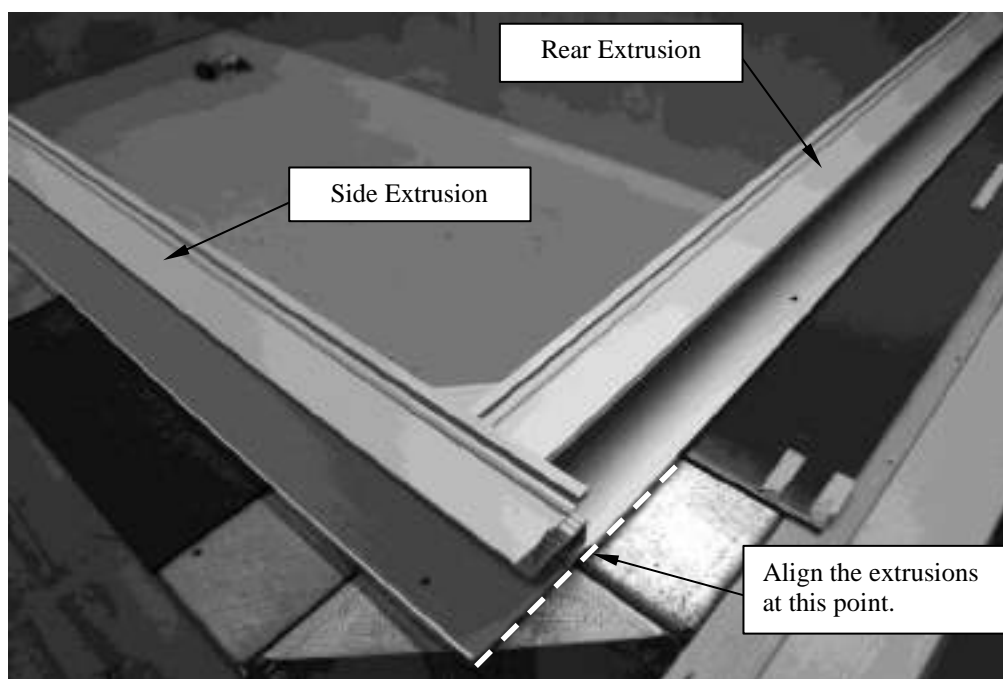

Fig 11

7. Align the extrusions so that the liner hanger is flush with the reinforcing channel. The extrusions should extend into the pool the thickness of the reinforcing channel everywhere else.
8. Secure all the extrusions and liner hangers with the provided self-drilling fasteners.
9. **At the front of the pool, the holes for the liner hanger/panel cover will have to be pre-drilled with an 11/64" (4mm) drill bit. Thread in the provided oval head stainless steel screws after the holes have been drilled**

10. Install the inside corner assemblies in each of the four corners. Begin by placing the triangular liner hanger piece and corresponding plastic shim onto the galvanized corner. Place this assembly into the corner of the pool so that the triangular liner hanger piece aligns with the liner hanger of the coping. While holding this assembly at the correct height, attach the galvanized corner to the pool wall with the provided tek screws. Then use the selfdrilling countersink screws to attach the triangular liner hanger piece into the galvanized corner through the plastic shim. (Fig 12)

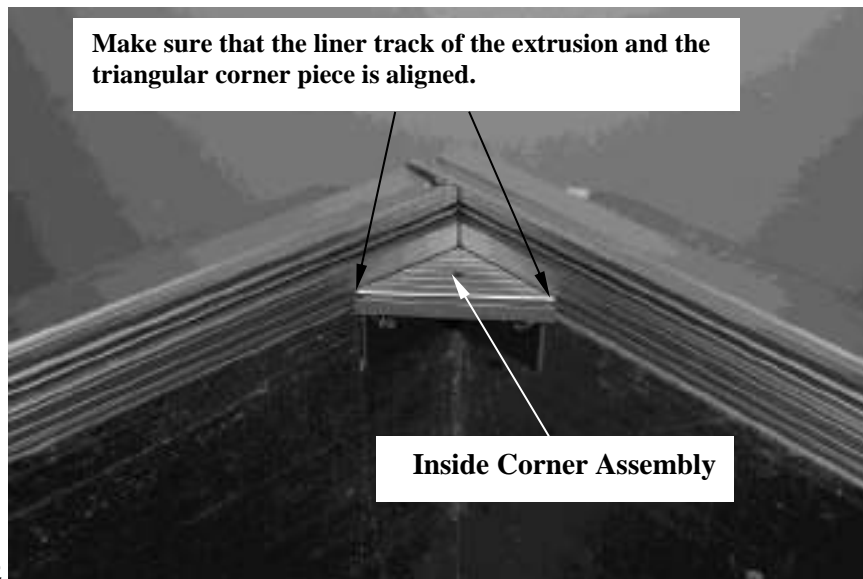

Fig 12

**Installing the Cover Fabric****DO NOT CUT THE FABRIC ROPE IF THE COVER IS NOT COMPLETELY OPEN!**

1. Take the cover fabric and position it so that the fabric's shiny side is facing down (resting on the water). The leading edge must be fed onto the fabric; therefore it must be done in an area with sufficient space. There is one end on the fabric that has a long rope extending beyond the fabric. Grab the fabric at that end and feed the beaded edge into the groove on the leading edge. The setscrews in the leading edge should be facing down. The leading edge needs to be centered on the cover fabric.
2. The long ropes at the end of the fabric should be fed through the black sliders attached to the leading edge. Push the slider down the rope to the cover fabric, so that it meets the webbing of the fabric before securing in place. (Fig 13)

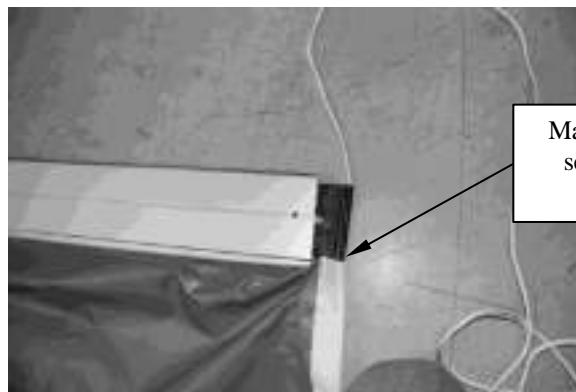

Fig 13

3. Insert two slider screws (Fig 14A) into each slider. (Fig 14B) Again, there should be no rope exposed between the slider and the end of the fabric.



Fig 14A

Slider Screw



Fig 14B

4. At the drive mechanism, loosen the track guide screws and remove the top half of the guide. The third screw on the guide must be loosened in order to remove the leading edge stop. This will allow the slider to pass the guide and into the track.

5. At the front of the cover, which is the end connected to the leading edge, there will be a length of rope exiting the fabric on each side. Make sure that there are no knots in the rope. Undo each of the knots on the ropes that are inside the combination cover track and liner hanger extrusions. **DO NOT PULL THE ROPES OUT OF THE EXTRUSION!** Take a roll of electrical tape and connect the rope attached to the cover to the rope that is closest to the inside of the pool. Connect the ropes end to end so that there is no overlap between the two. Repeat for the other side.
6. Once the ropes are connected, take the outside rope of the combination in-wall cover and liner track and pull towards you. This should fish the cover fabric rope through the cover track. Repeat for the other side.
7. Once the ropes are fed through, lift the leading edge up to the combination in-wall cover and liner track. Guide the slider through the track guides and into the cover track. Once the cover is at least two inches into the track, re-install the top half of the track guides and leading edge stops.
8. This step is best done with a helper. Pull each rope evenly so that the cover travels across the pool and the leading edge reaches the opposite end of the pool. When the cover is completely across the pool there should be approximately 2-3 feet (60cm-90cm) of fabric hanging out of the track at the mechanism end.
9. On the cover drum there is a weld seam with a small sheet metal screw securing the drum to the tapered hub. This screw is used to fasten the end fabric edge to the cover drum. Approximately 1" (25mm) from the end of the cover and at the seam of the fabric and beaded edge, secure the cover to the drum. Repeat for the other side. (Fig 15)

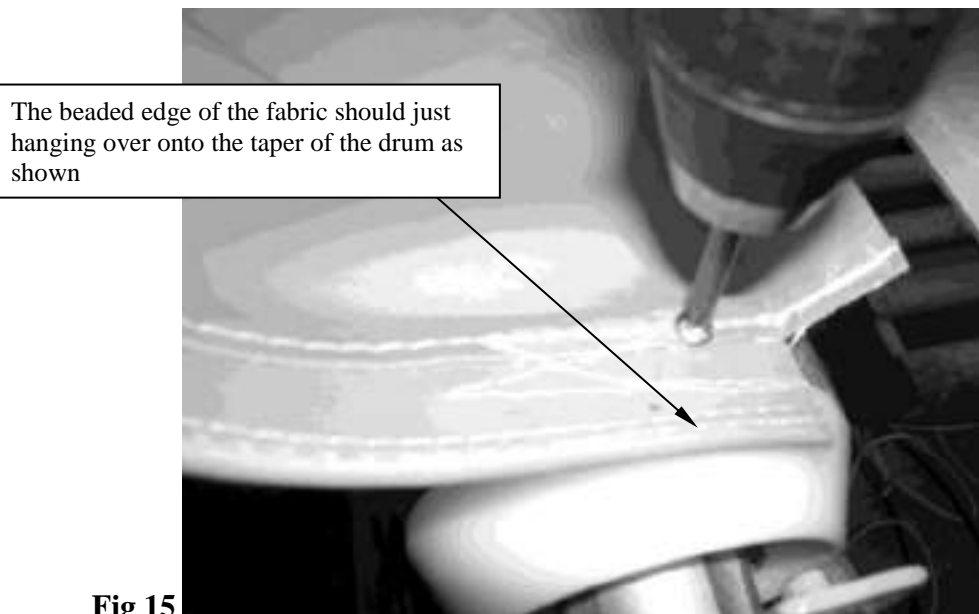
**Fig 15**

10. The cover drum has a series of pre-drilled holes in line with the end holes. Find the center of the cover by pulling it taut across the drum. Using the provided sheet metal screws, attach the center of the cover to the center hole of the drum. Start at the center and work towards either end attaching the cover to the drum by pulling the cover tight and securing to the drum using the sheet metal screws. When the last unused screw is reached, there will be excess fabric. Fold the excess cover onto itself and insert the sheet metal screw through the fold and attach to the drum. Repeat for other side. (Fig 16)

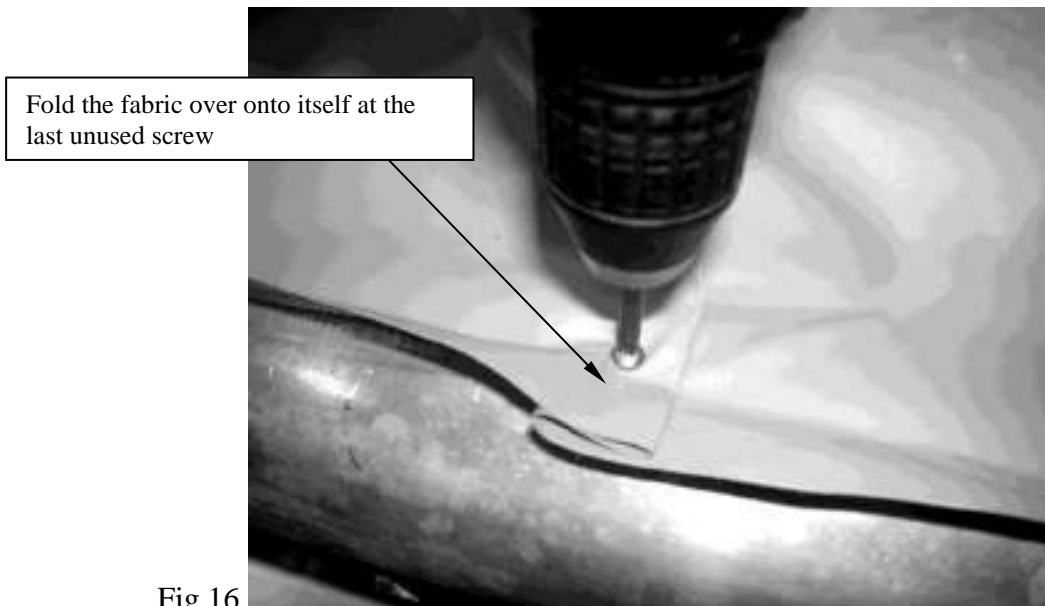

Fig 16

11. Ensure that the cover is evenly draped across the pool and the leading edge is centered between the tracks.
12. Make sure that the Power Unit has power. Turn the key to the OPEN position. This will pull the cover back off the pool. Hold the key in that position until just before the leading edge reaches the track guides.
13. There will be excess rope attached to the cover fabric. **DO NOT CUT THIS ROPE AT THIS TIME!**

### Installing the Cover Brackets

1. The C-Brackets will support any finish work above the cover at the front of the pool. They will be attached directly to the Z-braces (panel reinforcements) of the front panel. Site-specific factors will dictate their location, but they should be spaced evenly apart. 7' (2,13m) and 8' (2,44m) pools will get two C-brackets; 9' (2,74m) or wider will receive an extra bracket. Additional C-brackets can be purchased separately.
2. Draw a horizontal line 8 3/4" (22,22cm) down from the underside of the top flange on every Z-brace that will support a C-bracket.
3. The C-bracket assemblies are 2 pieces, a flat bracket and the C-bracket. Disassemble the C-brackets. Align the top hole in the flat bracket with the horizontal line on the Z-brace so that the flat bracket is seated firmly against the pool wall (Fig 17). Mark all the holes in the flat bracket on the Z-brace.

4. Use a 5/16" (8mm) drill bit to drill out each of these three holes for every Z-brace. Then use the provided hardware to attach the flat bracket to the Z-brace. (Fig 17)

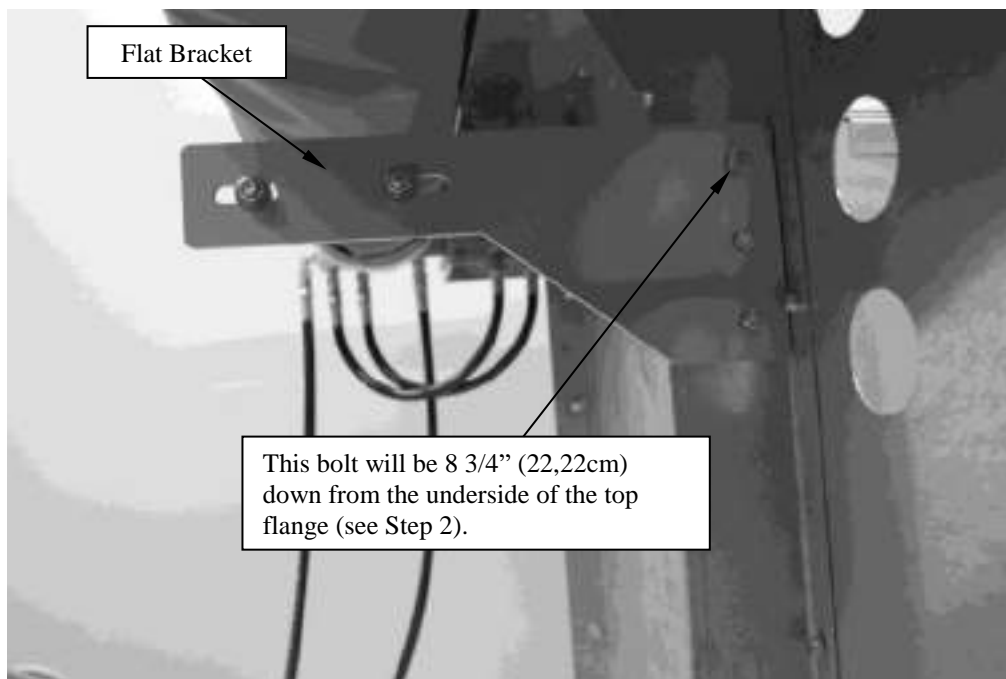

Fig 17

5. Bolt the C-bracket to the flat bracket. Make sure that there is a 1/4" (6mm) gap between the leading edge and top of the C-bracket. **Do not tighten bolts at this time.** (Fig 18)

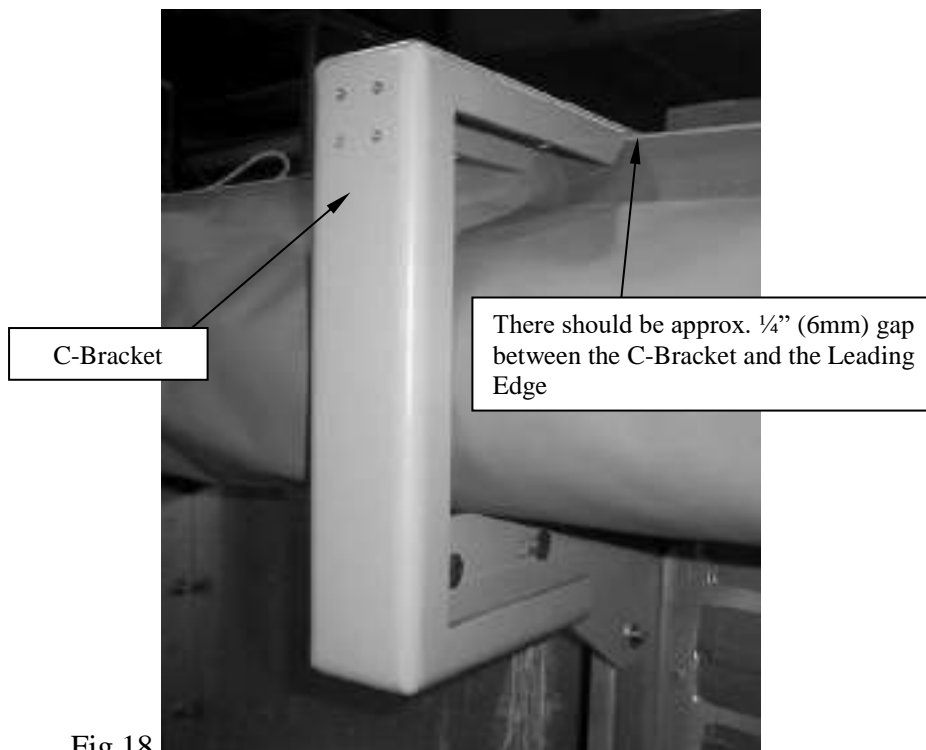

Fig 18



6. The top face of the C-brackets must be level with the end support brackets.
7. Line up the pulley channel to the drive assembly and C-brackets so that the hinged pulley assembly on the pulley channel is at the same end as the rope reel and drum motor assembly. Attach the pulley channel to the end brackets first using the provided hardware (Fig 17).
8. Depending on the depth of your pool, you may need to drill holes in the pulley channel for the C-bracket mounting bolts. First, make sure that both the pulley channel and C-brackets are level. Then mark the four holes in each of the C-brackets onto the pulley channel. This can be accomplished by inserting a fine tip marker and through the holes in the C-bracket (from the “inside” of the C-bracket) onto the pulley channel. Once marked, remove the C-bracket from the pool and drill out the four holes using a 1/4” (6mm) drill bit. Reattach the pulley channel to the cover mechanism and loosely attach all hardware.
9. Once assembled, level the pulley bracket (left to right) and C-brackets (back to front) and then tighten all hardware (Fig 19). The top surface of the both the C-brackets and the pulley channel must be in the same plane as the top surface of the combination in-wall cover track.

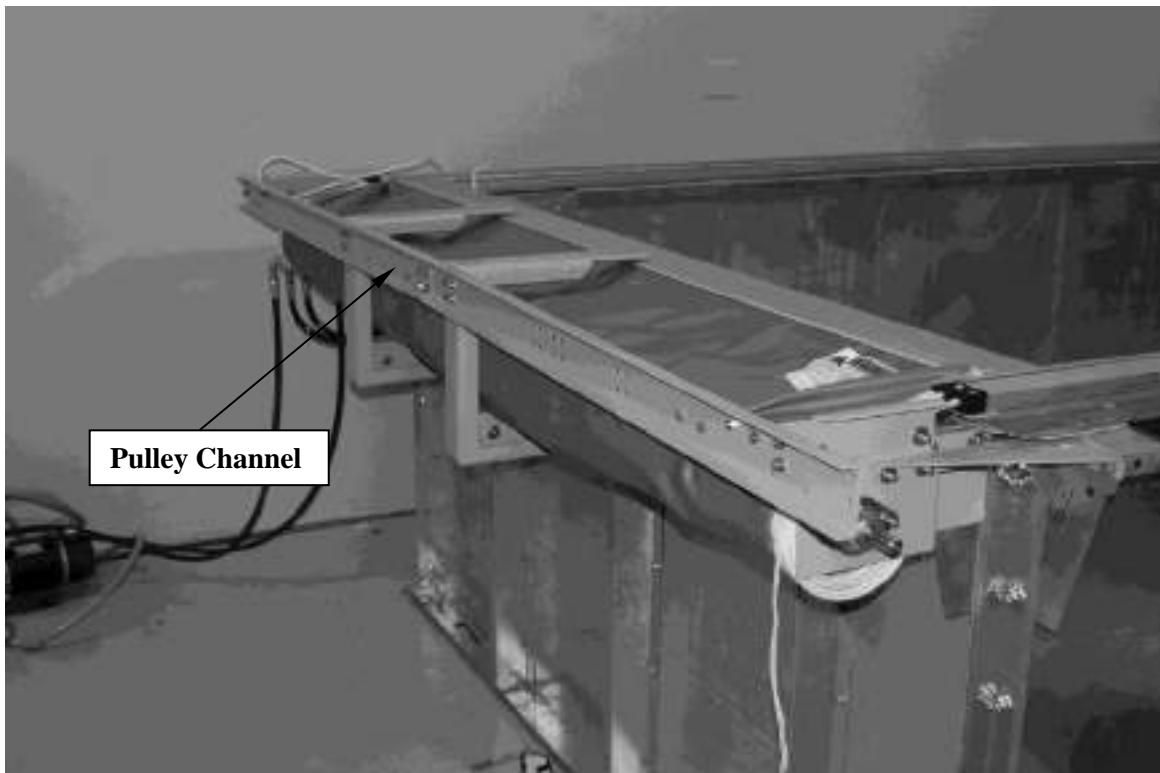

Fig 19

**Stringing the Pulleys**

1. The cover fabric should be fully rolled up onto the drum. Take the rope on the left side and pass it through the rope pulley directly in line with track guide exit. Feed the rope around the pulley towards the center compensating pulleys. Feed the rope down from the top, between the compensating pulleys, and back towards rope reel. At the double pulley bracket across from the rope reel, pass the rope from the back towards the front of the pulley furthest from the center and pass over the rope reel letting the rope fall to the floor.



Fig 20

2. On the right hand side, take the cover rope and feed it around the upper pulley directly in line with the track guide exit towards the center compensating pulleys. Feed the rope down from the top, between the compensating pulleys, back towards the right side of the pool (away from the rope reels). Then feed it around the lower pulley from the back towards the front. Bring the rope back across the width of the pool to the double pulley bracket across from the rope reel. At the double pulley bracket pass the rope from the back towards the front of the pulley closest to the center and pass over the rope reel letting the rope fall to the floor.

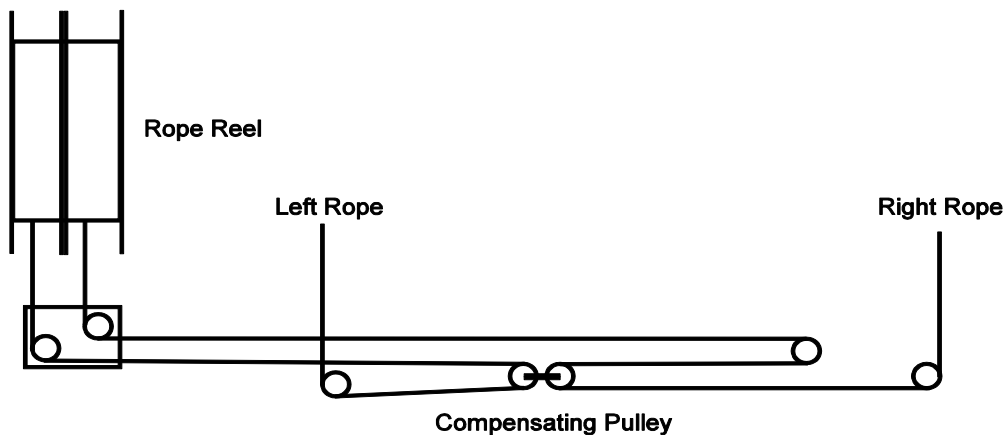

3. Pull both ropes taut across the cable reel and make sure that the compensating pulleys are centered in their slot. Wrap approximately 2"-3" (51mm-76mm) of electrical tape on each rope 24" (61cm) away from the reels. Cut each rope in the center of the tape and then burn the frayed end of both cables; which will fuse the rope ends.

4. Turn the momentary key switch to the CLOSE position until the two holes that are drilled in the reel center are facing up. Insert each rope into its corresponding hole and pull the excess through. Tie a knot at the end of each rope and pull the rope back out of the center until the knots are firmly against the reel.
5. This step is best done with a helper. Pull both ropes away from the reel and turn the key to CLOSE and feed the ropes evenly onto the reel and release just before the rope are fully on the reel. (Fig 21)

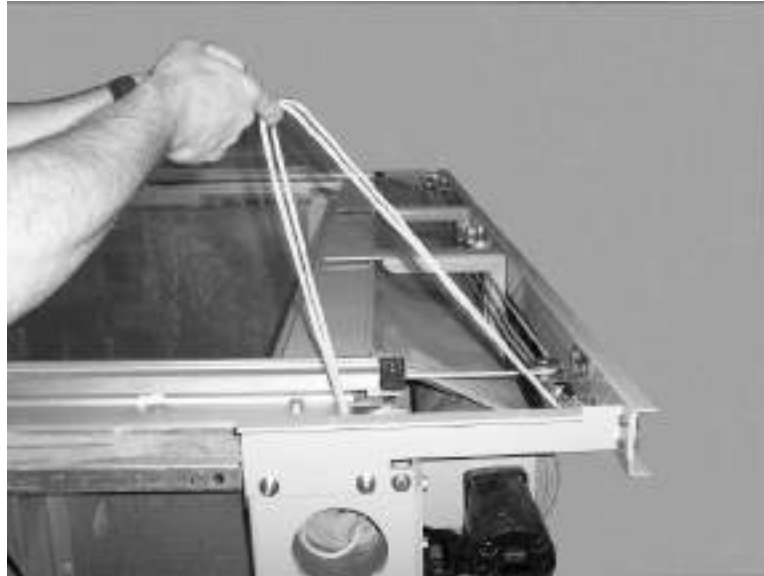

Fig 21

6. When the rope is tight on the reel turn and hold the key in the CLOSE position. This will pull the leading edge and cover across the pool. Release the key when the leading edge reaches the opposite side of the pool.

### Skew Adjustment

1. Turn and hold the key to OPEN. This will pull the cover back across the pool. If one side of the cover is winding up faster than the other, a skew adjustment is required. The cover drum is tapered on each end. The fabric being wound up on the wider part of the drum is being wound up faster than the fabric on the narrower part. If the fabric is coming back faster on the left side, then the drum has to be moved to the right or vice versa. Only move the drum a 1/8"-1/4" (3mm-6mm) per adjustment.
2. To move the drum, loosen the bolts securing the drive tube assembly to the cover reel assembly. Then slide entire drum assembly to adjust.
3. Re-tighten bolts and then test the system by turning the key to CLOSE. The leading edge should travel evenly back across the pool. Repeat this process as needed.

**Pressure Relief Setting on the Power Unit**

1. The pressure setting on the power unit should be high enough to move the cover back and forth across the pool, but low enough to stop the cover simply by grabbing the leading edge. This should be preset; however, an adjustment may be required. The relief valve is on the side of the power unit below the solenoid valve.
2. Loosen the lock nut and turn the relief valve with an Allen key. Turn the relief valve clockwise to increase the pressure and counter-clockwise to reduce the pressure. (Fig 22)
3. Once you have the correct setting be sure to tighten the lock nut while holding the relief valve with Allen key.

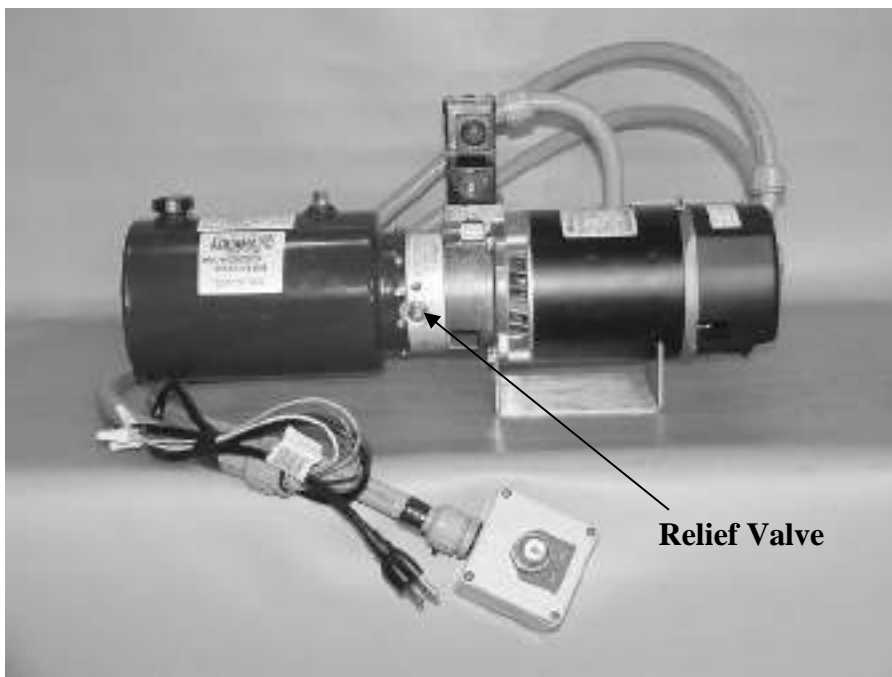

**Fig 22**