

# Hydramatic

## COMPACT DRIVE SYSTEM

Designed and Engineered  
by Aquamatic

*Another Industry First.  
Our Compact drive is designed for both  
recessed and retrofit applications.*



World Leaders in Automatic Pool Covers

# Compact Drive and Swim Spas



**Initially designed for the Swim Spa** application where the goal was to make the cover system proportional to reduce the size of the vessel. It is now ready for all types of pool/spa production.

The mechanism now requires only a 12" (past water line) offset on both sides of the mechanism housing. This addresses the aesthetics by equalling the offsets, and allows for better coping layout to accentuate symmetry around the pool/spa edge. Additionally, if you have minimal clearance, this unit addresses this challenge.

The Compact Drive is ideal for small to medium sized pools. For larger pools we can offer our standard Hydramatic in a split drive with an equal offset of 20" per side beyond waterline.

Limited to a maximum pool size of 14' x 28'.

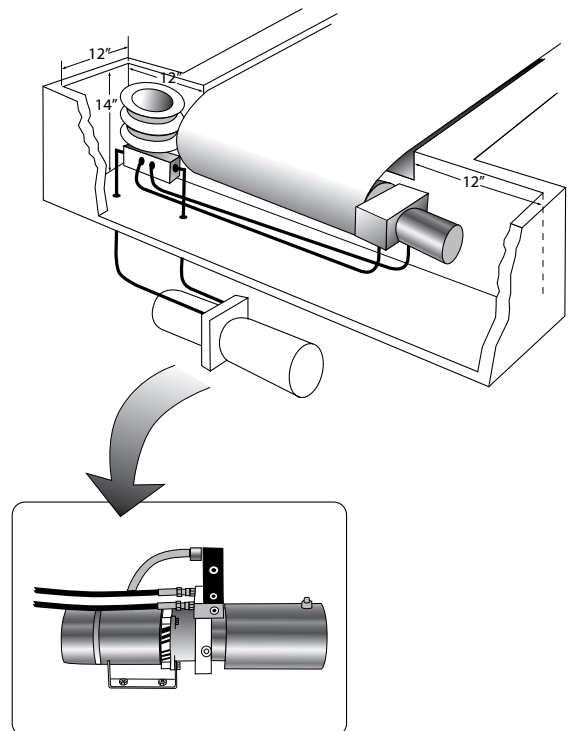



This Compact Drive utilizes Aquamatic proven dual motor hydraulic technology assuring you of the reliability and durability typical of our Hydramatic hydraulic drive system. It is also supported by the same 20 year limited mechanism warranty.



# Designed and Engineered by Aquamatic

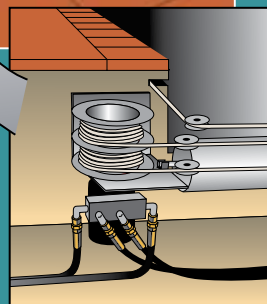
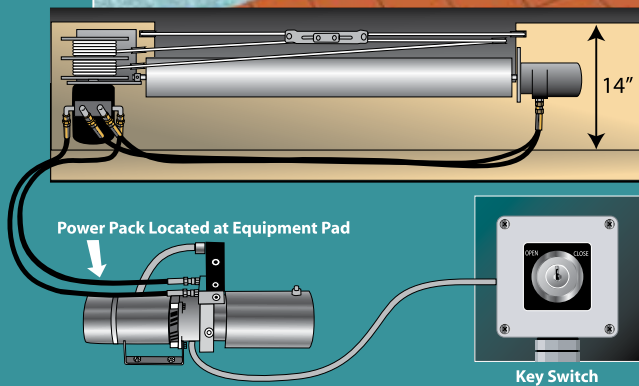
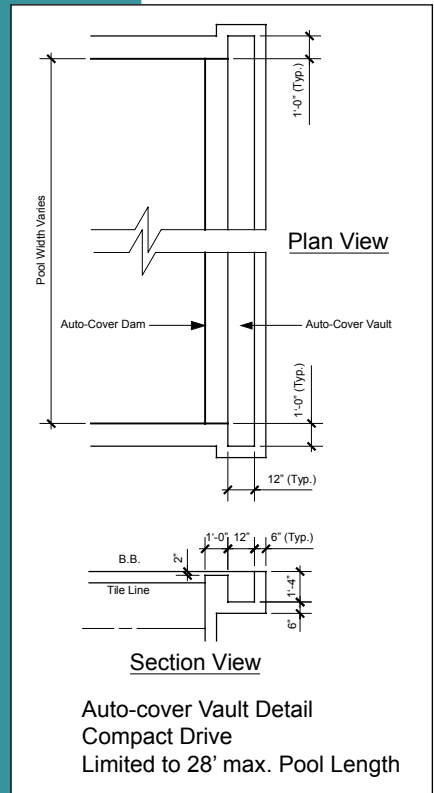
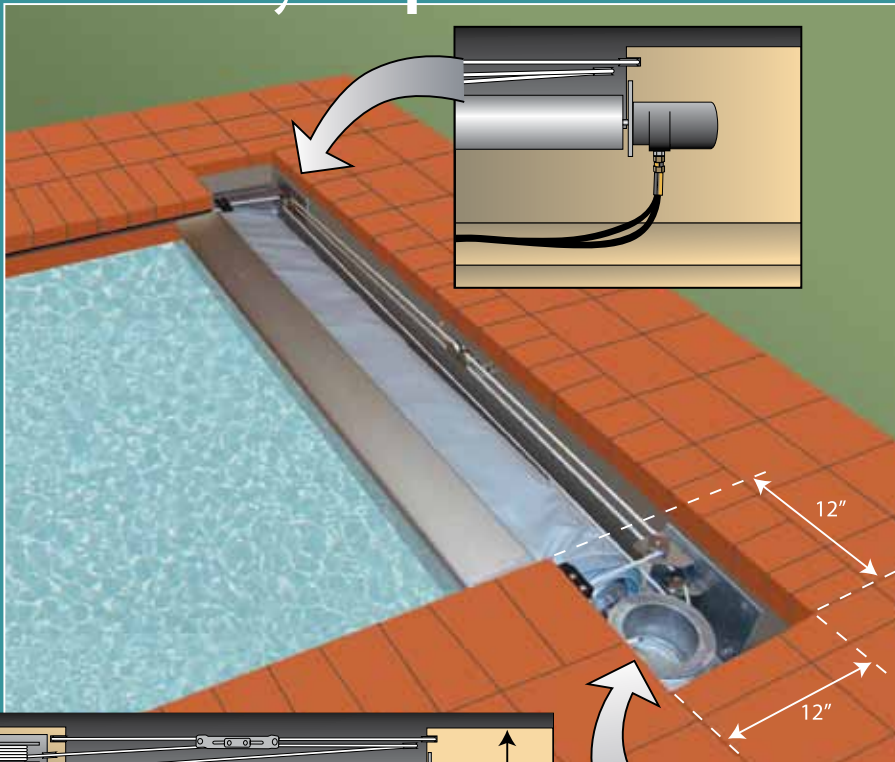



**Encapsulated "In-wall" Receptors for Concrete Gunite and Fiberglass Pools**

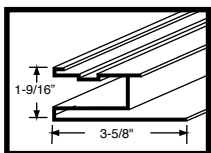

In-wall #4

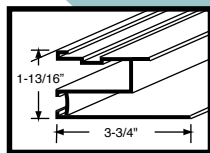

In-wall #5 w/Fiberoptic Receiver

In-wall tracking is ideal for any indoor or outdoor installation. The track receptor is installed on top of the bond beam during the pool construction prior to the coping installation. Coping or other masonry materials are placed directly on top of the track receptor.

On the deck mounted Compact Drive, the offset requires only 9" of clearance on both ends.

**Encapsulated "In-wall" Receptors for Vinyl Liner Pools**

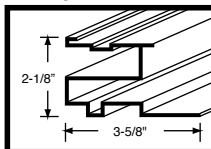

In-wall #21

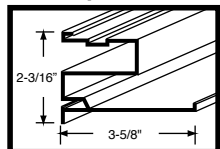

In-wall #31

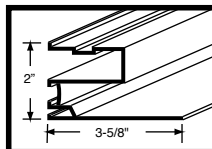

In-wall #6 w/Fiberoptic Receiver and Liner Bead

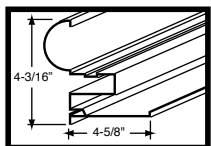

**In-wall 3DF**  
Incorporates track, liner bead and permanent deck form

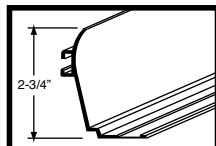

Reusable deck form can be used with any Aquamatic inwall track receptor

**Technical Specifications**

Exceeds ASTM F1346-91 safety standards

**Mechanism**

Drive unit 2 hydraulic torque motors  
Open and close switch Key-lock switch  
Powerpack (pump)

**Electrics**

110/220-240v-60/50 Hz,  
1PH 75-1.5 HP  
UL, CSA, CE approved  
ATF Dexron III  
800 psi (40-56 bar)  
pressure relief valves

Hydraulic oil  
Normal working pressure  
Limit switches

**Cover Fabric**

Material PVC on re-inforced polyester scrim  
Fabric weight 16/18 oz per sq. yd.

## STANDARD COLORS

Navy Blue



Royal Blue



Light Blue



Turquoise



Green



Tan



Brown



Black



Charcoal Gray



Gray



Sage Green



## DESIGNER COLORS

Washed Navy



Brushwood



Slate Gray



Buff



Russett Brown

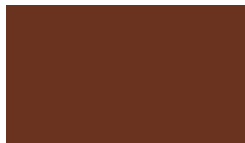

Dusty Blue



Hunter Green



Colors depicted on both the pool cover fabric as well as the composite polymer panels are as close as printing allows. Samples available upon request.

## BENCH AND COMPOSITE LID COLORS

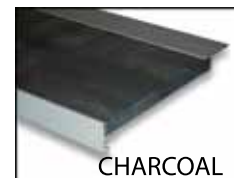
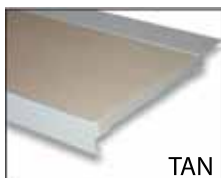

## POWDER COATING COLORS (These match the lid colors above)

Ral-9010

Ral-1019

Ral-8004

Ral-8012

Ral-7040

Ral-7012

\* Powder Coating is a non-warranted item\*



# Features of our patented Dual-Motor, all fluid Compact Hydraulic Cover Drive System

## *Advantages and Benefits*

---

### **WATERPROOF**

The Hydramatic drive is a closed loop system, and although a drain is required in the cover recess, inadvertent flooding does not mean expensive electric motor replacement.

### **SAFETY**

No electrics near the pool for greater safety. All electric power and switches are remote at the equipment pad which also means fewer problems with inspections.

### **POWER**

Hydraulic drives are compact yet powerful, and can be easily controlled to provide only as much as is needed to operate the cover. Hydraulics are durable, and the most popular drive unit for wet and hostile environments and are the preferred choice of builders, designers and architects.

### **DURABILITY**

Hydraulics are widely used in heavy equipment for their durability and reliability. The unique patented Dual-Motor Hydramatic system eliminates mechanical linkage and clutches to start and then change direction of the cover. It has the least number of parts of any other automatic pool cover system, yet has a full range of safety and convenience features. Originally designed for commercial and other high use applications exclusive to Aquamatic.

### **CONVENIENCE**

The Hydramatic cover system has a patented built-in rainwater removal feature on most applications. When rainwater collects on the cover surface, simply turn the key to open the cover, and the water will be forced through the screens into the pool. The screen mesh will collect the leaves and most debris. A computerized cover pump is also provided with all cover systems exclusive to Aquamatic.

### **COVER TRAVEL LIMITS**

The cover is gently and reliably stopped at each end of travel by our patented pressure relief valves, eliminating the need of electronic sensors or other electrical devices near the pool.

### **RATED**

The Hydramatic cover is UL tested and certified to exceed ASTM F1346-91 standards for pool safety.

### **WARRANTY**

The cover system comes with a limited 20 year warranty on the mechanism, a limited 7 year warranty on the covers and a limited 10 year warranty on the polymer panels. For additional information, contact your Aquamatic representative.

---



# Other Benefits

## Saves Lives

An Aquamatic cover acts as a horizontal fence, and it is "safety you can see". The primary function of the automatic cover has always been to safeguard your children and pets from the pool and minimize the risks inherent with pool ownership. The ICC has recently recognized automatic covers as stand alone barriers. Additionally both the Hydramatic and the EZ-Cover exceed ASTM F1346-91 standards for safety and closure. As durable as these are, they are not intended as a toy and should only be walked on in an emergency. Of course there no substitute for adult supervision.



## Saves Energy

The U.S. Department of Energy states that 75 % of heat loss is from evaporation, along with the evaporation, you will have water and chemical loss while incurring the cost of increased pump and filtration time of an uncovered pool. By utilizing an automatic pool cover you will eliminate your evaporative loss.

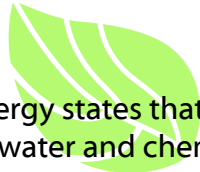

## Saves Money

An automatic cover will reduce your pool operating costs by as much as 70 % through reduction of water, chemical and energy consumption. Additionally your other pool equipment will work less and last longer. You will also realize a full return on your cover investment in a relatively short time. \* On indoor pools, the automatic cover will act as a vapor barrier, which allows you to reduce both the size and operating time of your dehumidification equipment saving you additional money. \*

## Saves Time

Spend less time skimming and more time swimming. A pool with a cover is always clean, warm and debris free. Which in turn, will allow you to have more time to enjoy your backyard oasis with your friends and family.



## Saves Resources

The pool cover will act as a solar collector and will passively heat your pool through radiant transfer. Our customers have found on average their pool temperature has increased by as much as 10 to 15 degrees while also extending their swimming season.

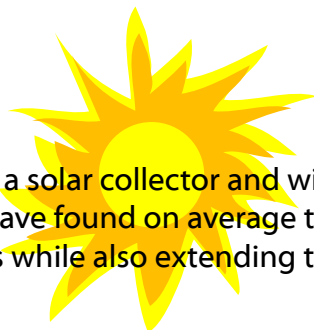





# Aquamatic Cover Systems



200 Mayock Road • Gilroy, CA, USA 95020

Ph: 800.262.4044 / 408.846.9274

Fax: 800.600.7087 / 408.846.1060

[www.aquamatic.com](http://www.aquamatic.com)

This product is covered by one or more of the following patents  
7,748,215; 6,496,990; 6,390,680; 5,845,343; 5,546,751; 5,349,707; 5,327,590; 5,184,357; 5,067,184; 4,939,798  
Other U.S. and foreign patents pending

**Automatic & Manual Covers Since 1980**  
**Distribution and Installation Available Worldwide**