

3/4 HP HYDRAULIC POWER-PACK (part # 500H) 110/220 Volt

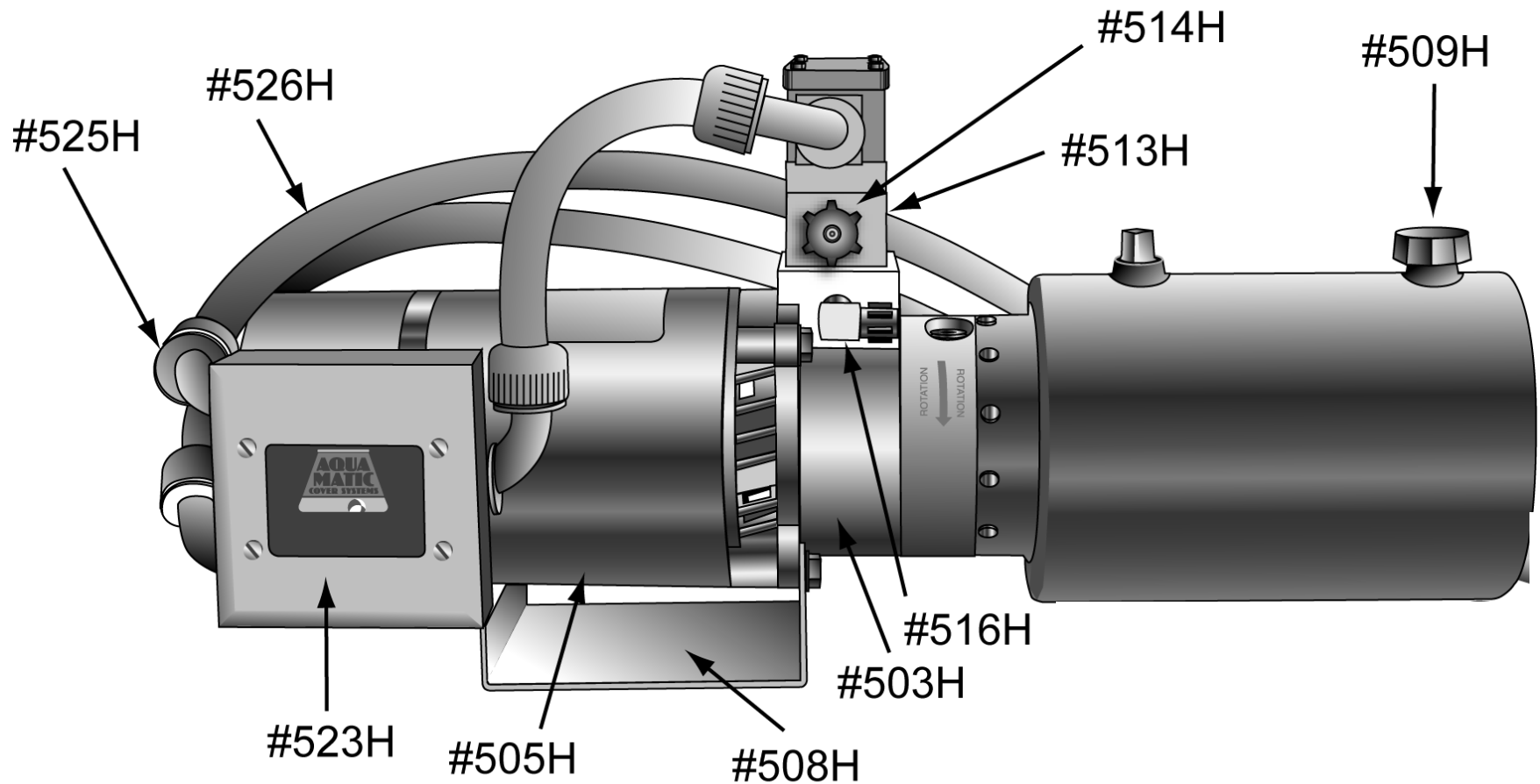

Power-pack Specifications

Length = 26" Wide = 10" Tall = 11"

Weight = 50lbs 110V/220V

UL,CSA, CE approved

Hydraulic Oil = EPA approved biodegradable

Normal working pressure = 800 psi

Limit switches = pressure relief valves

Operational Switch = Momentary Switch

Parts Description

#503H	Hydraulic Pump
#505H	Electric Motor
#508H	Power-pack Stand
#509H	Breather Cap
#513H	Solenoid Valve
#514H	Solenoid Magnet
#516H	Solenoid Valve Fitting
#523H	Double Gang Junction Box
#525H	Liquid Tight Connector
#526H	Liquid Tight Flex Conduit